



POWER TO CONQUER

Quality Skid Steer Loaders



VIKING WORKMATE PERFORMANCE

HYDRAULICS

Pump Sizes	13.8cc
Hydraulic Pressure	3200psi
Hydraulic Capacity	40 litres
Max Travel Speed	11.7km/h
Rate Lift Capacity	365kg swl
Wheel Motors	4 x 470cu

ENGINE

Petrol	Kohler 27HP Carburetor
Fuel Tank	25 litres

DIMENSIONAL SPECIFICATIONS

Overall Width (A)	950mm with 8.5" wheel 740mm with 8.5" (skinny)
Overall Length (B)	1600mm
Overall Height (C)	985mm
Max. Operating Height (D)	2165mm
Angle of Departure (E)	20 degrees
Wheel Base (F)	800mm
Ground Clearance (G)	120mm (8" tyre)
Max. Pin Height (H)	1990mm
Dump Height - Std Bucket	1940mm
Dump Height (4 IN 1 Bucket)	1900mm
Height to Hinge Pin	2000mm
Tyre Size	18" x 8.5" x 8" (standard) or 19" x 8" x 10" big wheel (optional)
Filtration	Replaceable cartridge
Machine Mass	750kg wet
Angle alarm Sensor	Optional
Security Immobiliser	Optional

WARRANTY

Engine	3 years or 2000hrs
Product	2 years or 1000hrs

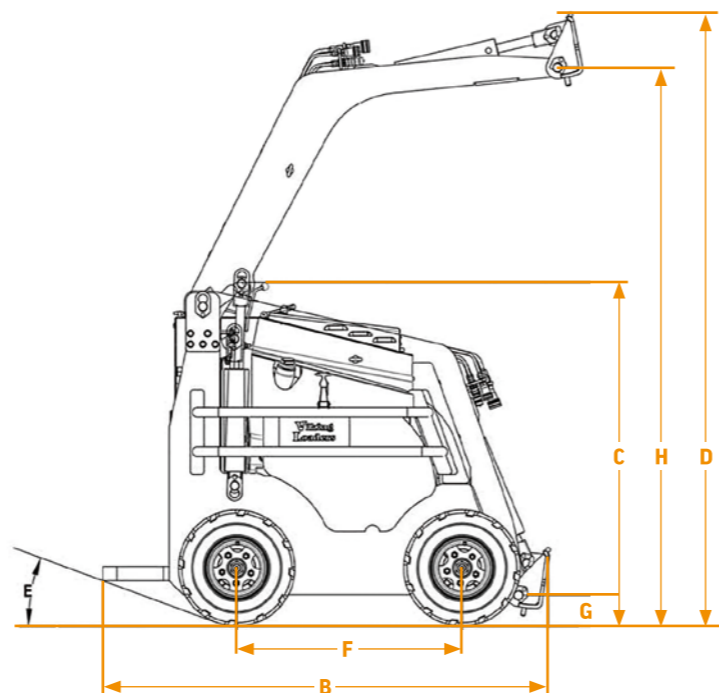
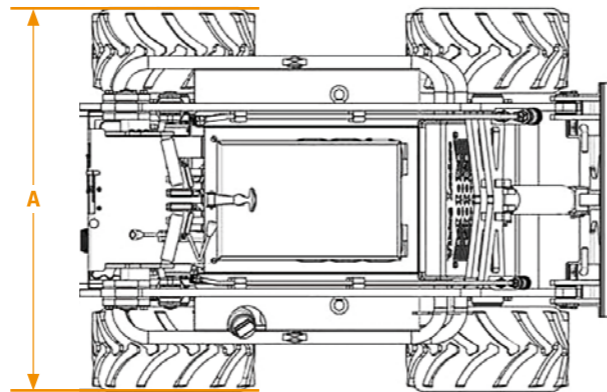

POWER TO CONQUER

Quality Skid Steer Loaders



WORKMATE

POWERED BY

KOHLER

Viking Mini Loaders Pty. Ltd.
 Factory 25/172 Canterbury Road,
 Bayswater North Victoria 3153
 T 03 9720 2264
 F 03 9720 2265
 E sales@vikingminiloaders.com.au
vikingminiloaders.com.au



The Viking Workmate is designed to make operators more productive. Viking Loaders achieve this by using good ergonomic mechanical design, combined with innovative hydraulic design, and world class components.

WORKMATE

CHASSIS

- + The narrowest contractor mini skid steer loader - 950mm wide standard or 740mm wide fitted with skinny wheels
- + 16mm fabricated steel chassis
- + 8mm belly pan
- + 1.9mm dump height
- + Low centre of gravity
- + Ergonomically designed control layout
- + Large operator platform - very spacious

HYDRAULICS

- + Innovative high performance, Industrial hydraulic system
- + Very efficient high flow design
- + Fully integrated one piece control valve
- + Variable speed trencher control valve
- + Single high pressure pump
- + Twin- High flow & low flow remote auxiliary ports
- + 500 hr hyd service interval
- + Individual wheel motor access
- + Large 5kw thermo hydraulic cooler with fan

POST HOLE DIGGER



ENGINE

- + 27HP V-Twin Air Cooled Petrol Engine, application tested and international warranty approval.
- + Easy access for maintenance
- + Full-pressure lubrication, delivering positive lube to engine component. Up to 25 degrees of operation.

COMPONENTS

- + Cartridge Air filter
- + Billet Steel Hubs
- + Hinged Bonnet for easy access
- + Pivoting Grill Assembly
- + Plastic moulded fuel tank
- + Built for Australian conditions

ATTACHMENTS

- + Trencher
- + Stump Grinder
- + 4 IN 1 Bucket
- + Grapple
- + Power Rake
- + Sift Bucket
- + Back Fill Blade
- + Bucket Broom
- + Post Hole Digger



VIKING MINI LOADER
WORKMATE
CONTROL PANEL